

# SCIENTIFIC AMERICAN

---

Ultrahigh-Speed Rotation

Author(s): Jesse W. Beams

Source: *Scientific American*, Vol. 204, No. 4 (April 1961), pp. 134-149

Published by: Scientific American, a division of Nature America, Inc.

Stable URL: <https://www.jstor.org/stable/10.2307/24937429>

---

JSTOR is a not-for-profit service that helps scholars, researchers, and students discover, use, and build upon a wide range of content in a trusted digital archive. We use information technology and tools to increase productivity and facilitate new forms of scholarship. For more information about JSTOR, please contact [support@jstor.org](mailto:support@jstor.org).

Your use of the JSTOR archive indicates your acceptance of the Terms & Conditions of Use, available at <https://about.jstor.org/terms>



*Scientific American*, a division of Nature America, Inc. is collaborating with JSTOR to digitize, preserve and extend access to *Scientific American*

JSTOR

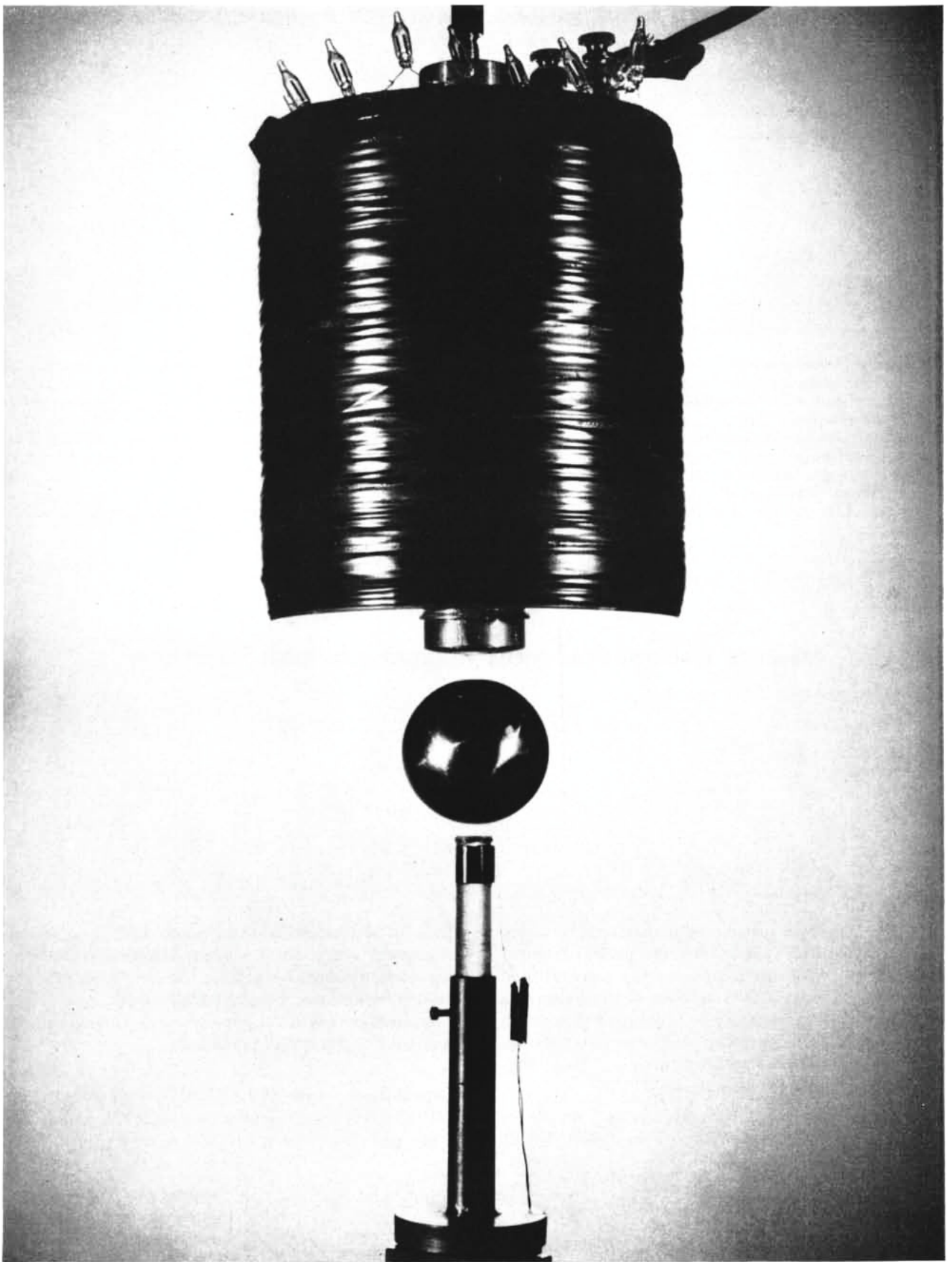

STEEL BALL ROTOR two inches in diameter is supported in mid-air by electromagnet above it. A coil below senses the rotor's position and changes the strength of the electromagnet to hold

position constant. In operation the rotor is sealed inside a vacuum chamber and rotated by electromagnetic forces. All photographs accompanying this article were made in the laboratory of the author.

# Ultrahigh-Speed Rotation

*Centrifuges have now been made that can spin a tiny rotor 1.5 million revolutions per second. The evolution of these machines has provided instruments for a variety of scientific and technological applications*

by Jesse W. Beams

To the physicist high-speed rotation is not an end in itself; it is a means for solving scientific or technological problems. But making things spin at ever higher speeds has been fascinating in its own right, and this is the topic of my article. Over the years I have had many able colleagues and students; their ingenuity is reflected in many of the mechanisms I shall mention.

Our fastest machines can spin tiny rotors to speeds of about 1.5 million revolutions per second (not minute). These rotors, which have a peripheral speed of some 2,500 miles per hour, finally explode. Since they are only about a hundredth of an inch in diameter (smaller than the period at the end of this sentence) no serious damage is done. A peripheral speed of about 2,500 m.p.h. seems to be the maximum that can be achieved with ordinary spherical rotors and the strongest steel alloys now available. At top speed the peripheries of these small rotors are subjected to an acceleration of more than a billion times that produced by the earth's gravity. By using still smaller rotors we could obtain a still higher acceleration and for some of our current experiments we may try to achieve it.

Physicists use acceleration in a special sense, which should be explained, along with two other concepts: centripetal force and centrifugal force. When a boy swings a stone on a string, the stone is said to be in a centrifugal field. The force acting on the stone, however, is a centripetal force—it is directed inward to the center of rotation, or inward along the string. The centrifugal force is the equal and opposite force that the boy feels pulling his arm outward.

Whenever force is applied to a free object, the object is accelerated. If a body is moving in a straight line and a

force is applied in the direction of motion, the body will move faster, or accelerate. But a force is also required to make a body change its direction, even if its speed is unchanged. Thus the physicist also regards a change in direction as an acceleration. In other words, he regards velocity as having both magnitude

and direction; a change in either or both represents an acceleration. It is for this reason that a body rotating at constant speed is said to be accelerating constantly; and the acceleration is centripetal. Except at velocities approaching the speed of light, the centripetal acceleration of a mass is proportional to the cen-

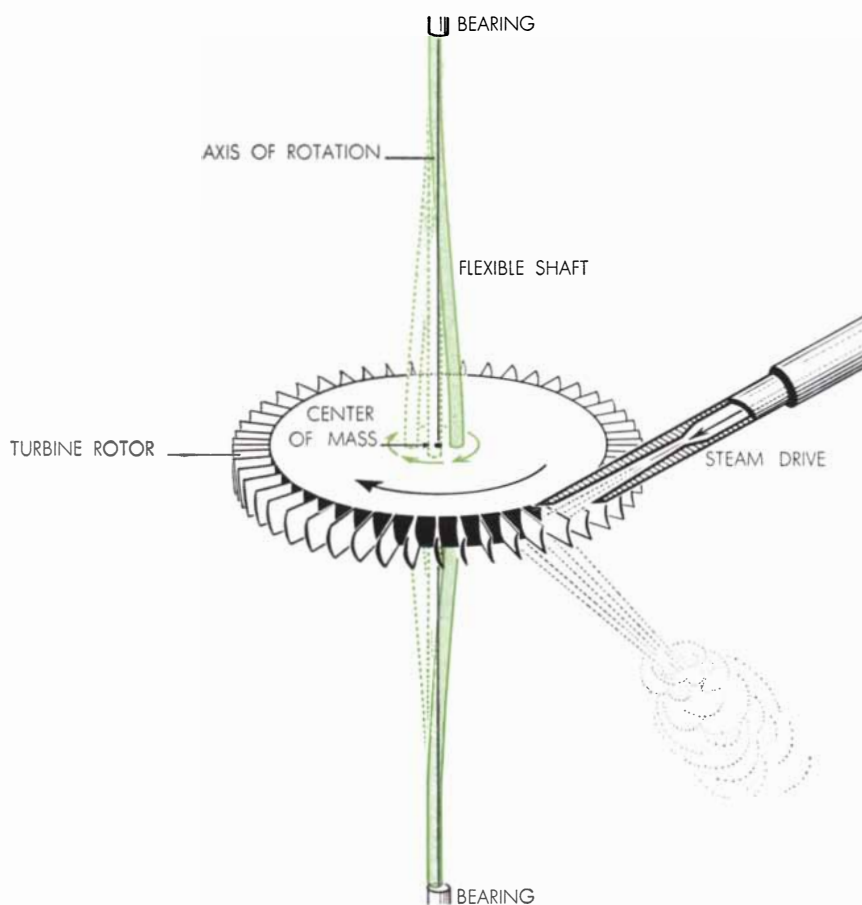

**FLEXIBLE-SHAFT TURBINE**, invented by Carl G. P. de Laval in 1883, overcame problems of lack of balance in the rotor and vibration associated with stiff shafts. The flexible shaft permits the rotor to seek its "own axis of rotation" and spin about its center of mass.

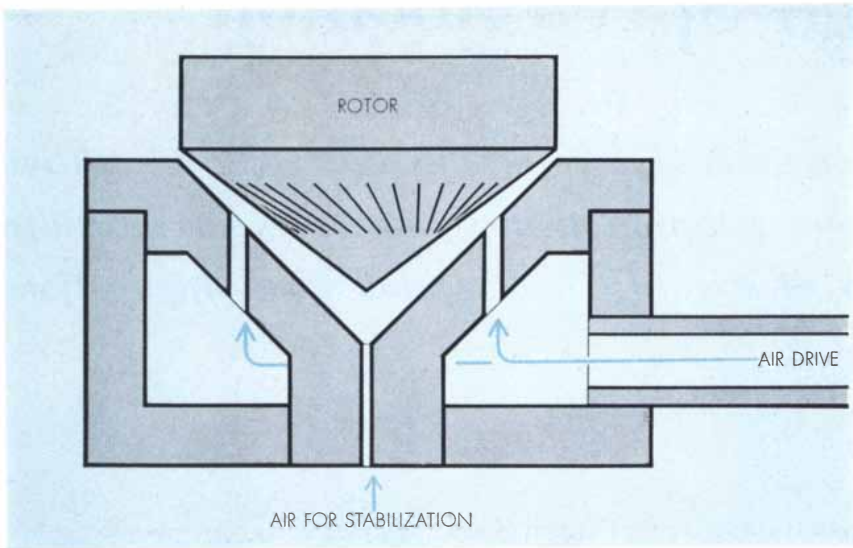

**SMALL AIR-DRIVEN ROTOR**, designed in 1925 by E. Henriot and E. Huguenard of Belgium, is supported by a jet of air. Flutings milled into the rotor enable air to make it spin. Rotors an inch in diameter can be spun up to speeds of 4,000 revolutions per second.

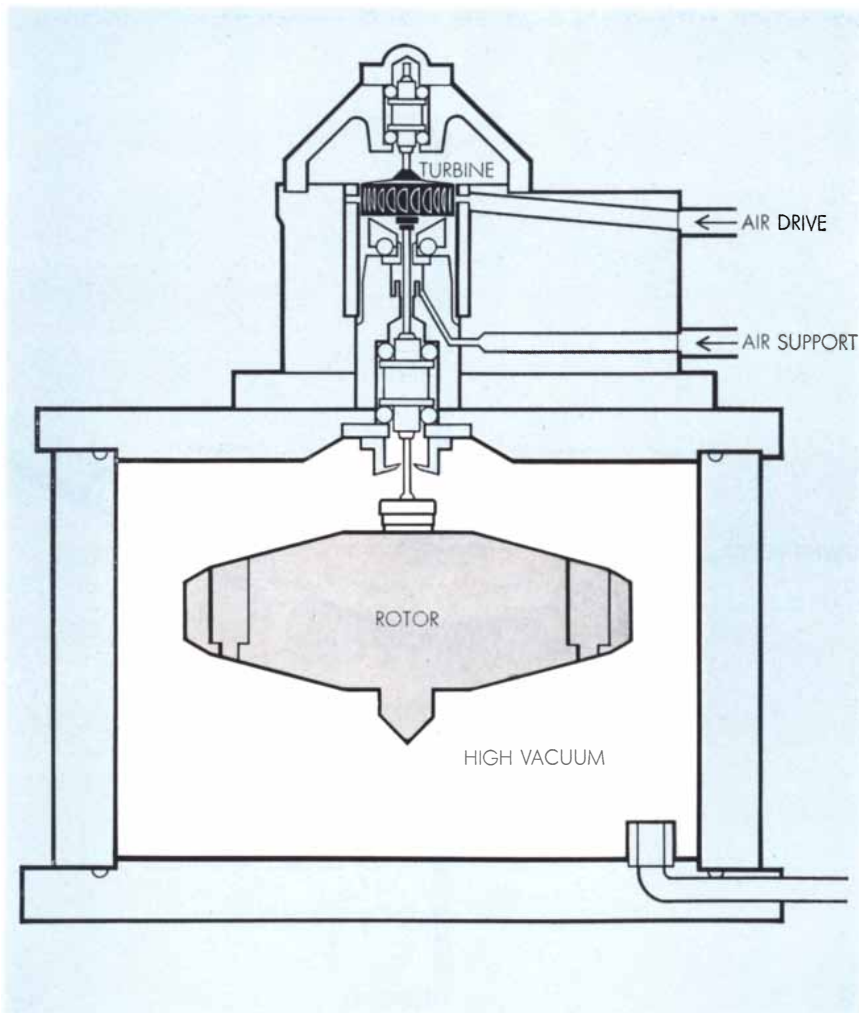

**EARLY ULTRACENTRIFUGE**, designed by the author and his students, could spin rotors up to 10 inches in diameter at 1,000 r.p.s. The rotor, housed in a vacuum chamber, is spun by an air-supported, air-driven turbine. Rotor and turbine are joined by a flexible shaft.

tripetal force. It is convenient to express centripetal acceleration in terms of the standard acceleration of gravity at the surface of the earth. This value, called  $g$ , is about 32 feet (or 980 centimeters) per second per second. When the rims of our small rotors are being subjected to a centrifugal field of a billion  $g$ , they are undergoing centripetal accelerations of 32 billion feet per second per second.

In the past century the maximum rotational speeds attainable have increased from under 500 revolutions per second (r.p.s.) to the present figure of about 1.5 million. In comparison, the wheel of an automobile traveling 60 m.p.h. rotates at about 12 r.p.s.; the crankshaft of an automobile engine, up to 100 r.p.s.; the turbine rotor of a jet engine, up to about 200 r.p.s.

One might think that a rotor mounted on a simple shaft could be driven to almost any desired speed. Actually such a design runs into grave difficulties. If the rotor is even slightly unbalanced, large forces are exerted on the bearings holding the shaft, causing them to fail. More serious still, if the shaft is stiff, the rotor and shaft are easily set to vibrating like a violin string, which also leads to failure. Since it is extremely difficult to damp these vibrations if the imbalance is appreciable, in most practical cases they place a relatively low limit on rotor speeds.

The first designer to find a way around these twin problems was the Swedish engineer Carl G. P. de Laval. In 1883 he substituted a long flexible shaft for the conventional stiff shaft and built a small steam turbine capable of rotating at 700 r.p.s. The complete theory explaining why De Laval's design works is highly complex, but what it amounts to is that a flexible shaft will permit even an unbalanced rotor to spin about a line passing approximately through the rotor's center of gravity. This axis is often referred to as the body's "own axis of rotation."

A number of De Laval's small early turbines were used to drive cream separators. Later De Laval used the flexible-shaft principle in his famous single-stage steam turbine [see illustration on preceding page]. In these larger machines he obtained rotor speeds of more than 400 r.p.s. and a peripheral speed of 1,300 feet per second, several hundred feet higher than competitive turbines. The extra speed gave De Laval's units a big edge in efficiency, for efficiency increases steadily until the peripheral speed of the

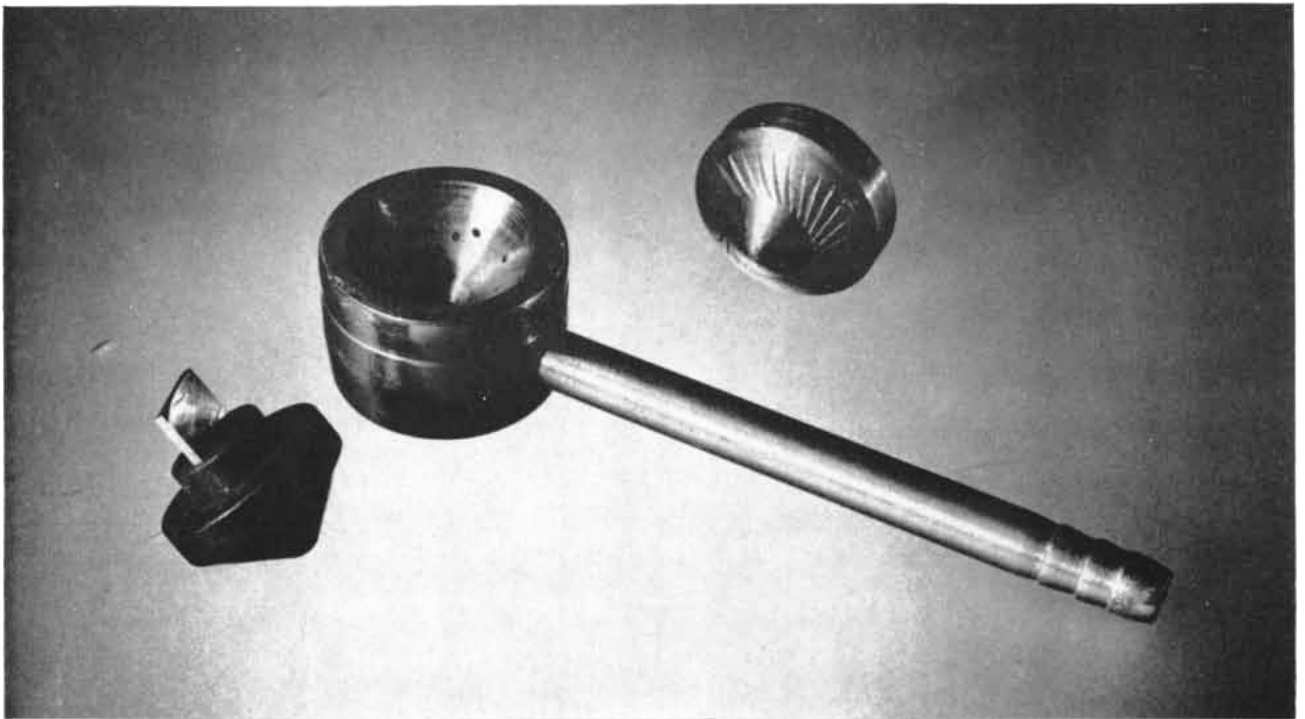

CONE-SHAPED ROTORS designed by Henriot and Huguenard carry a mirror, as at left, for light experiments. Compressed air

enters stator (*center*) through a tube. The flutings that cause the rotor to spin can be seen on the underside of the plain rotor.

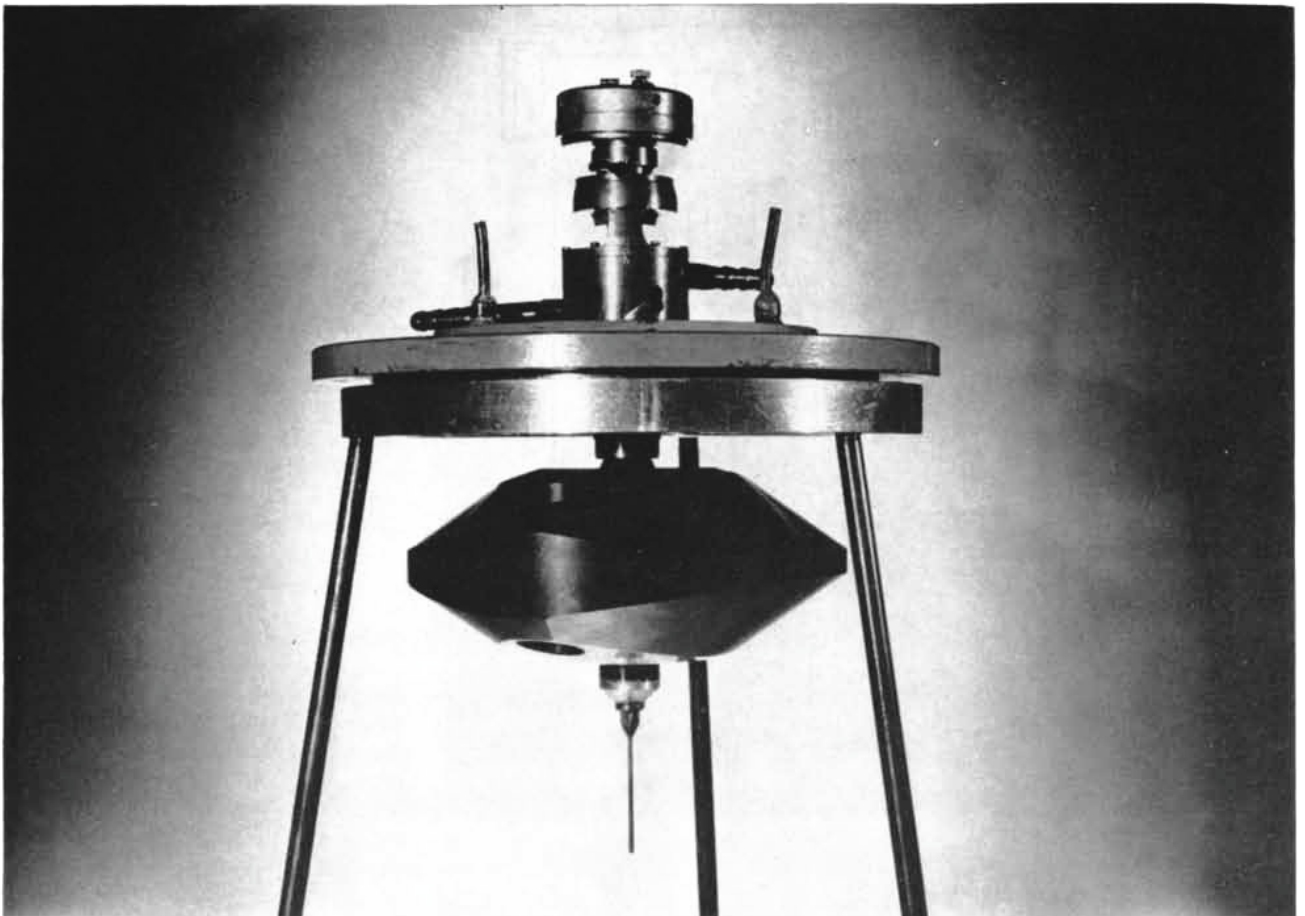

OLDER ULTRACENTRIFUGE of type shown in diagram at bottom of preceding page has a turbine driven by compressed air. The

vacuum housing in which rotor spins has been removed here so that the rotor can be seen. This mechanism was designed in about 1934.

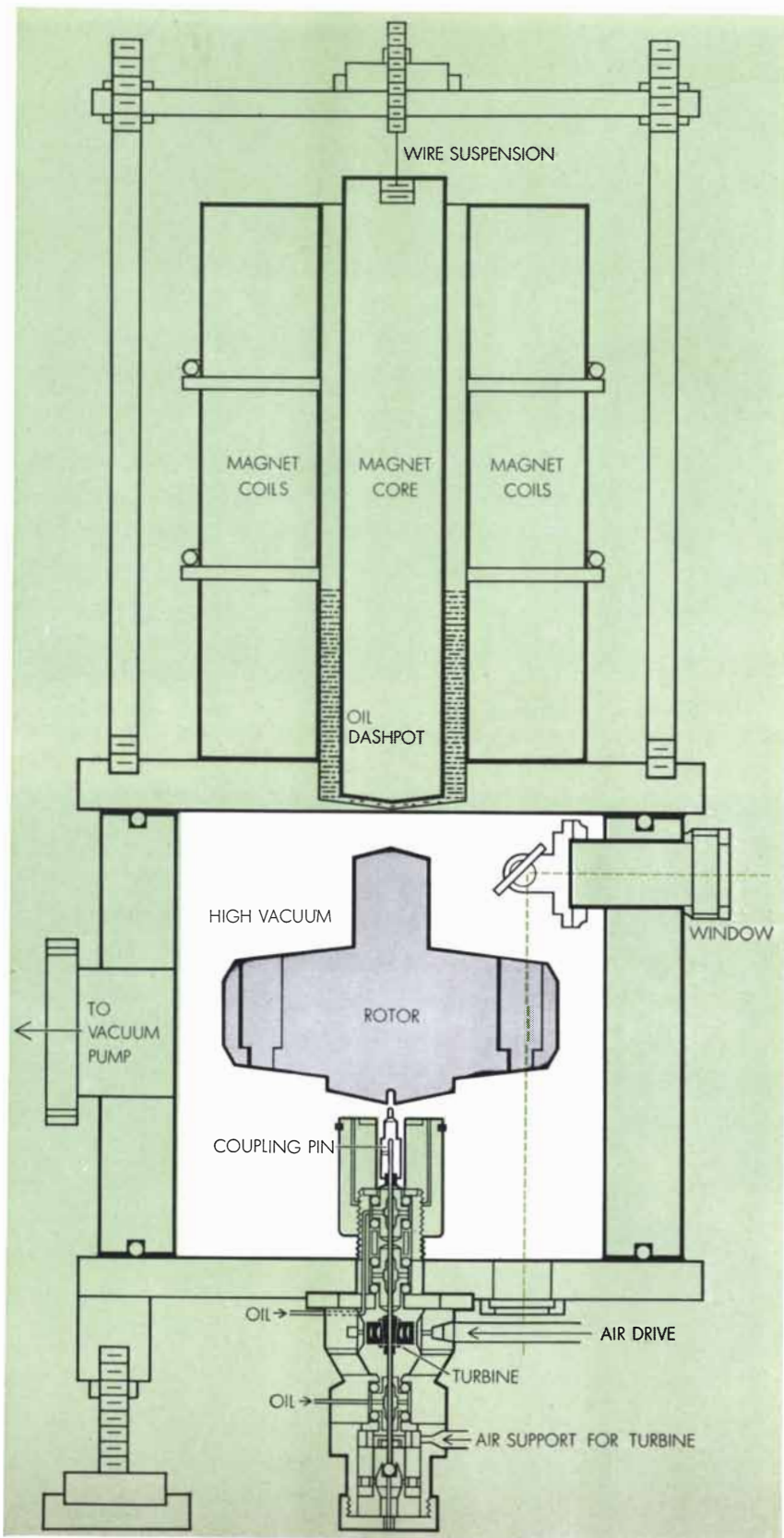

**MAGNETIC SUPPORT SYSTEM** in an air-driven ultracentrifuge lets the rotor coast freely after it is spun up to full speed and disengaged from drive shaft, as shown here. Unless forcibly decelerated, the rotor would spin for years. Magnetic core in oil dashpot supports rotor and damps drift. Window permits observation of sedimentation of sample in rotor.

turbine reaches about half the speed of the steam jet.

The next significant advances in high-speed rotation came in the 1920's. At the University of Uppsala in Sweden, Theodor Svedberg began building the first of the machines he called "ultracentrifuges," designed to measure molecular weights. The machines incorporated a system of lenses for making photographic records of the sedimentation rate of substances as viewed through a window in the spinning rotor. (A modern system for this purpose is illustrated on page 146.) To reduce friction and minimize the build-up of temperature, the rotors were sealed in a chamber containing hydrogen at a pressure of a few millimeters of mercury (atmospheric pressure is 760 millimeters). The first of Svedberg's ultracentrifuges to give good sedimentation data were electrically driven and rotated at about 170 r.p.s. Over the next few years Svedberg built oil-driven units that turned at more than 1,000 r.p.s. and produced centripetal accelerations as high as 900,000 g. Because he never adopted the flexible-shaft principle his machines required the greatest care in design and workmanship. Partly for his investigations of giant molecules, Svedberg was awarded the Nobel prize in chemistry in 1926.

In the previous year two Belgian workers, E. Henriot and E. Huguenard, had conceived the simple idea of spinning a small fluted rotor on a jet of air [see top illustration on page 136]. The rotor is raised from its resting place by the airstream and automatically seeks a position in space where its weight is just counterbalanced by the pressure of air from below. The rotor is constrained from flying off to one side or the other, or out of the stator cup, by the operation of Bernoulli's principle, which states that if the speed of a fluid stream is increased, its pressure must decrease. Thus if the rotor should begin drifting to one side, the air velocity would increase on the side opposite and fall in pressure; the rotor would then move back in the direction of reduced pressure. Since the rotor is not connected to a shaft, moreover, it is free to seek its own axis of rotation. By this means Henriot and Huguenard were able to spin small rotors, an inch or less in diameter, to several thousand revolutions per second and to produce centrifugal fields of around a million g.

It was this system that came to our attention in the late 1920's, when Ernest O. Lawrence and I were looking

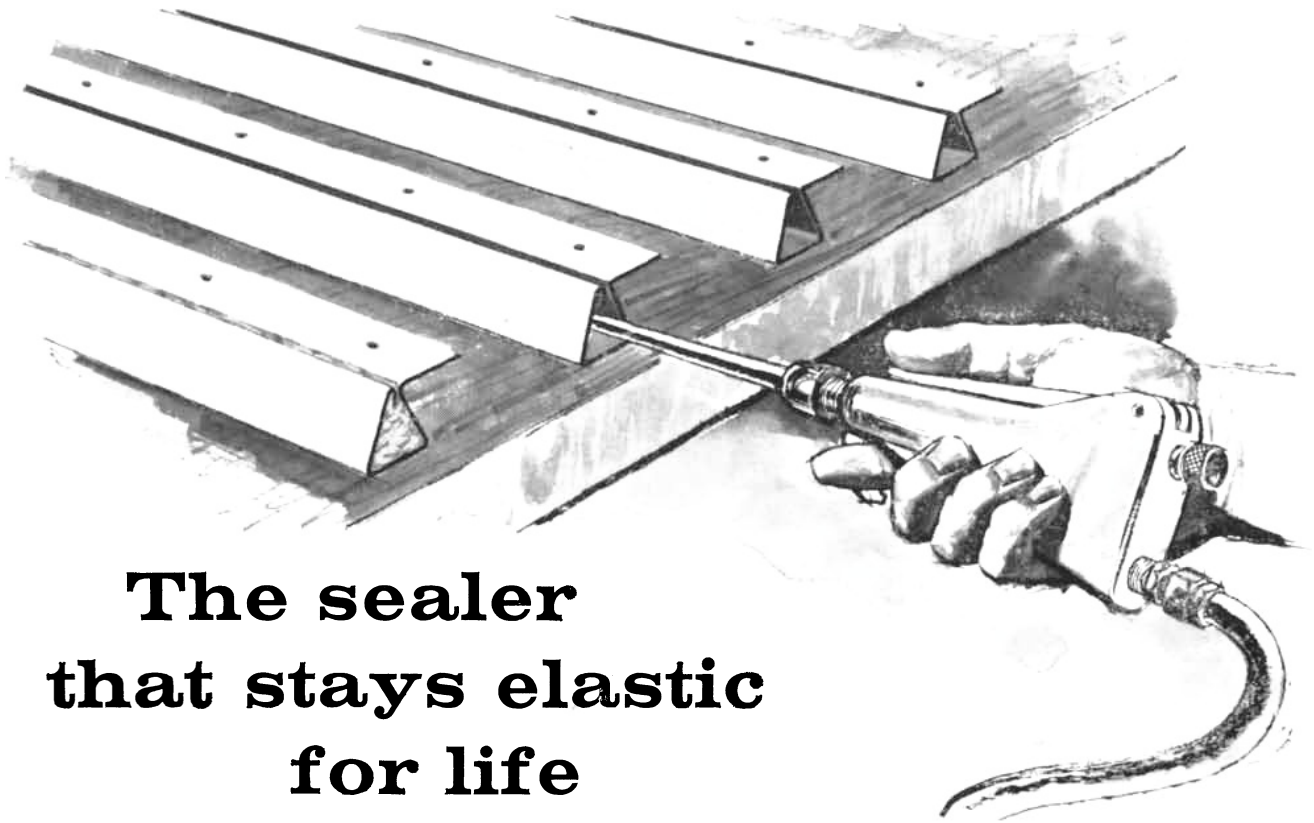

## The sealer that stays elastic for life

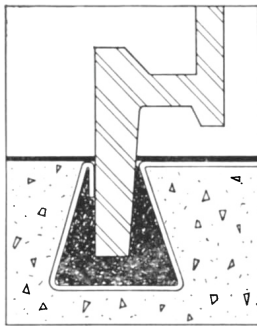

The sealing compound used in internal, inaccessible joints must give permanent, dependable service.

Sealant failure in such "hidden" joints means trouble. Refilling is costly, if the joint can be reached at all. The only practical answer to such problems is to do the job

right the first time with a sealer that never quits—a sealer like Armstrong's new P-606.

A California firm\* put this lasting quality of P-606 to good use in developing a new method for installing metal window frames. Metal joint channels, pre-filled with P-606 at the factory as shown above, are imbedded in concrete at the building site. Window frames are then inserted into the channels, forming a lasting, weatherproof seal, and eliminating job site caulking.

The secret of P-606's success in such applications is simple. It stays elastic, eliminating the major cause of sealant failure—drying out and cracking. P-606 does the job right

the first time and lasts the life of the joint. P-606 has excellent adhesion to most materials—metal, glass, rubber, concrete—and it retains this characteristic through extensive aging at temperatures from 160° to -40° F. Shrinkage is negligible since P-606 is more than 90% solids. And P-606 stays where you put it without slumping. Applied with a hand gun or pressure pump system, P-606 forms an effective, permanent seal against air, dirt, dust, and moisture.

These superior properties have made this sealer suitable for a wide range of uses. Voids in air conditioners are filled with P-606 to reduce vibration and prevent air leaks. Riveted truck trailer joints are permanently sealed with P-606. It is even used by a pre-fabricated home manufacturer to seal unexposed joints between concrete wall sections.

In many cases, P-606 costs less than the sealant previously used. Maybe you have a sealing job that could be done better and more economically with P-606. We will be glad to advise—and furnish samples of P-606—if you will submit full details of the application to the Armstrong Cork Company, 8004 Inland Road, Lancaster, Pennsylvania.

\* Name supplied on request

**Armstrong ADHESIVES**

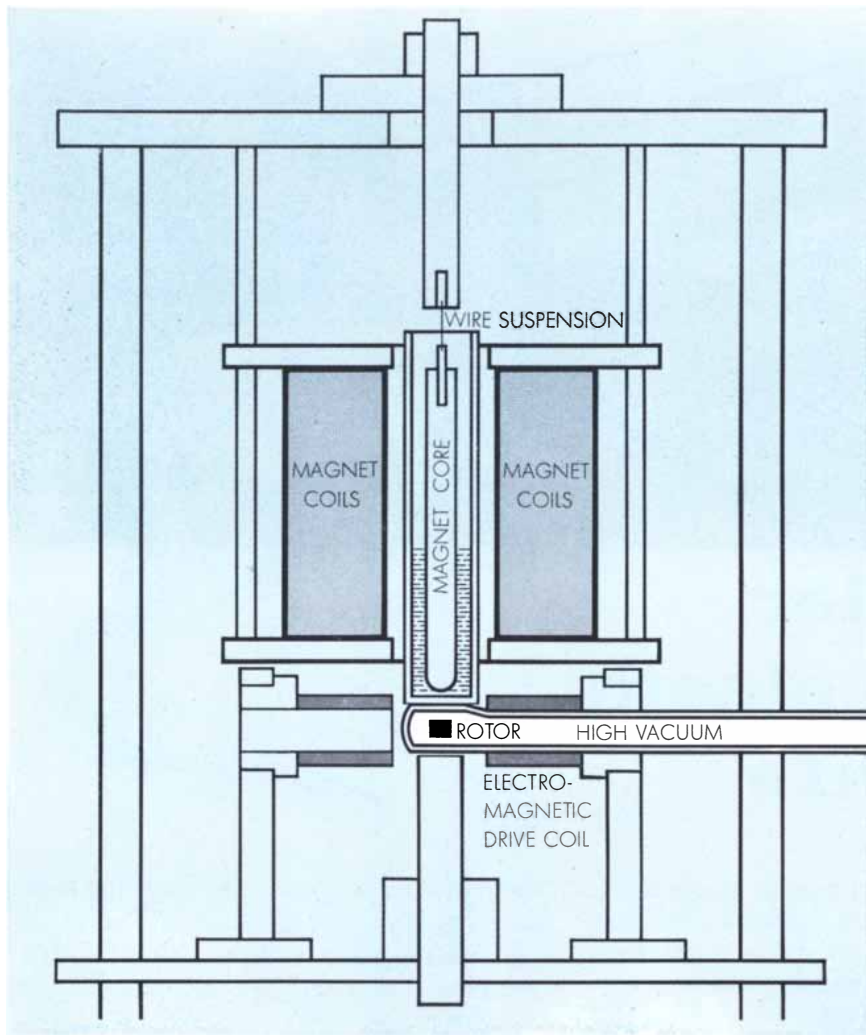

SHAFTLESS ROTOR made of ferromagnetic material is suspended in magnetic field and is spun, like the armature of an induction motor, by electromagnetic force. Small rotor can reach 1.5 million r.p.s. Magnetic core in oil dashpot prevents horizontal drift of rotor.

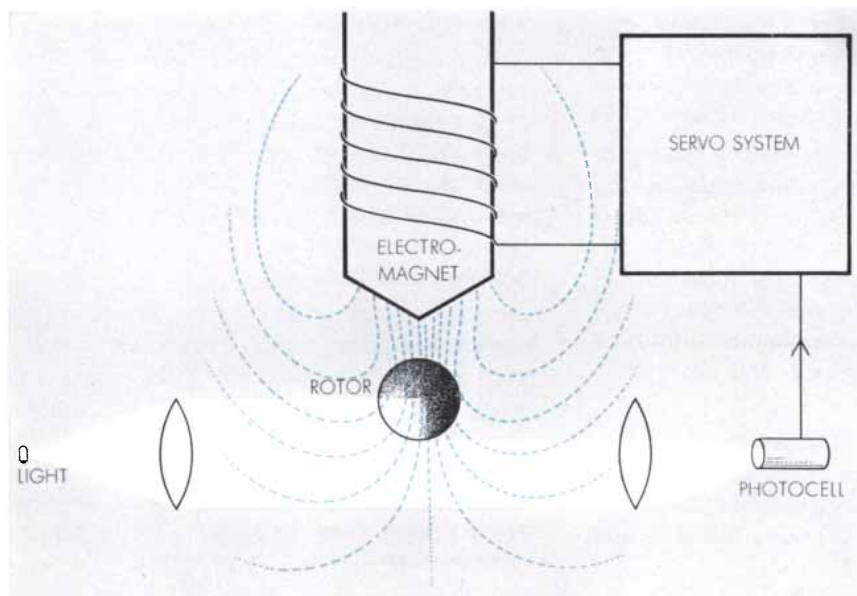

OPTICAL CONTROL of vertical drift of rotor is exerted by photocell. If rotor moves up or down, amount of light reaching photocell changes, activating a circuit to change strength of electromagnet that holds rotor up. System works so well rotor cannot be seen to drift.

for a way to make high-speed photographs of the breakdown of electric sparks and of other phenomena of very brief duration. By mounting a mirror on an air-driven rotor we were able to build a high-speed camera that met our needs. This was my introduction to high-speed rotation.

The question naturally arose as to whether we could use a simple air-driven rotor for sedimentation measurements of the Svedberg type. The answer proved to be yes, but the air drive had many drawbacks. If the rotor speed is high, the air or gas friction becomes so great that the rotor will not reach high speeds unless it is small or unless much power is used to drive it. In either case air friction heats the rotor unevenly and tends to set up convection currents in the solution being analyzed, spoiling the results.

We undertook, therefore, to build ultracentrifuges in which the rotor could be spun in a high vacuum. We found we could spin a large rotor (up to a foot in diameter) by sealing it inside a vacuum chamber and driving it by a small air-supported, air-driven turbine located either above or below it [see *bottom illustration on page 136*]. We also adopted De Laval's idea of the flexible shaft to connect the turbine to the rotor. This allowed the rotor to seek its own axis of rotation. One of the most difficult problems in this design, finally solved, was development of a practical vacuum-tight oil gland for the shaft to pass through. The design of our vacuum-type ultracentrifuge has gone through many modifications and, in improved commercial versions, can be found in many laboratories. The usual commercial model spins a seven-inch rotor up to about 1,000 r.p.s., producing a centrifugal field of a few hundred thousand *g*. Ultracentrifuges of this general type have been the principal work horses of molecular sedimentation experiments in this country for the past 25 years.

Within the past dozen years many of the air-driven and electrically driven models have incorporated a magnetic-support system [see *illustration on page 138*]. After the rotor is spun up to operating speed, the air or electrical drive coupling is disengaged and the rotor coasts freely, supported only by a magnetic field. It turns out that the friction in this magnetic support "bearing" is too small to be measured. A 30-pound rotor coasting at 1,000 r.p.s. in a high vacuum (a millionth of a millimeter of mercury) will lose only about 1 r.p.s. in a day. Essentially all the slowing down is due to friction with the air remaining in the vacuum chamber.



The ideal rotor drive would be one that did not need a turbine and could therefore be shaftless. The rotor, resting on a friction-free bearing, would freely seek its own axis of rotation at speeds limited only by the rotor's inherent strength. This ideal, of course, cannot be

completely achieved. Starting in 1937, however, a number of other workers and I at the University of Virginia began developing magnetically supported, electromagnetically driven rotors that closely approached the ideal.

These rotors, made of ferromagnetic

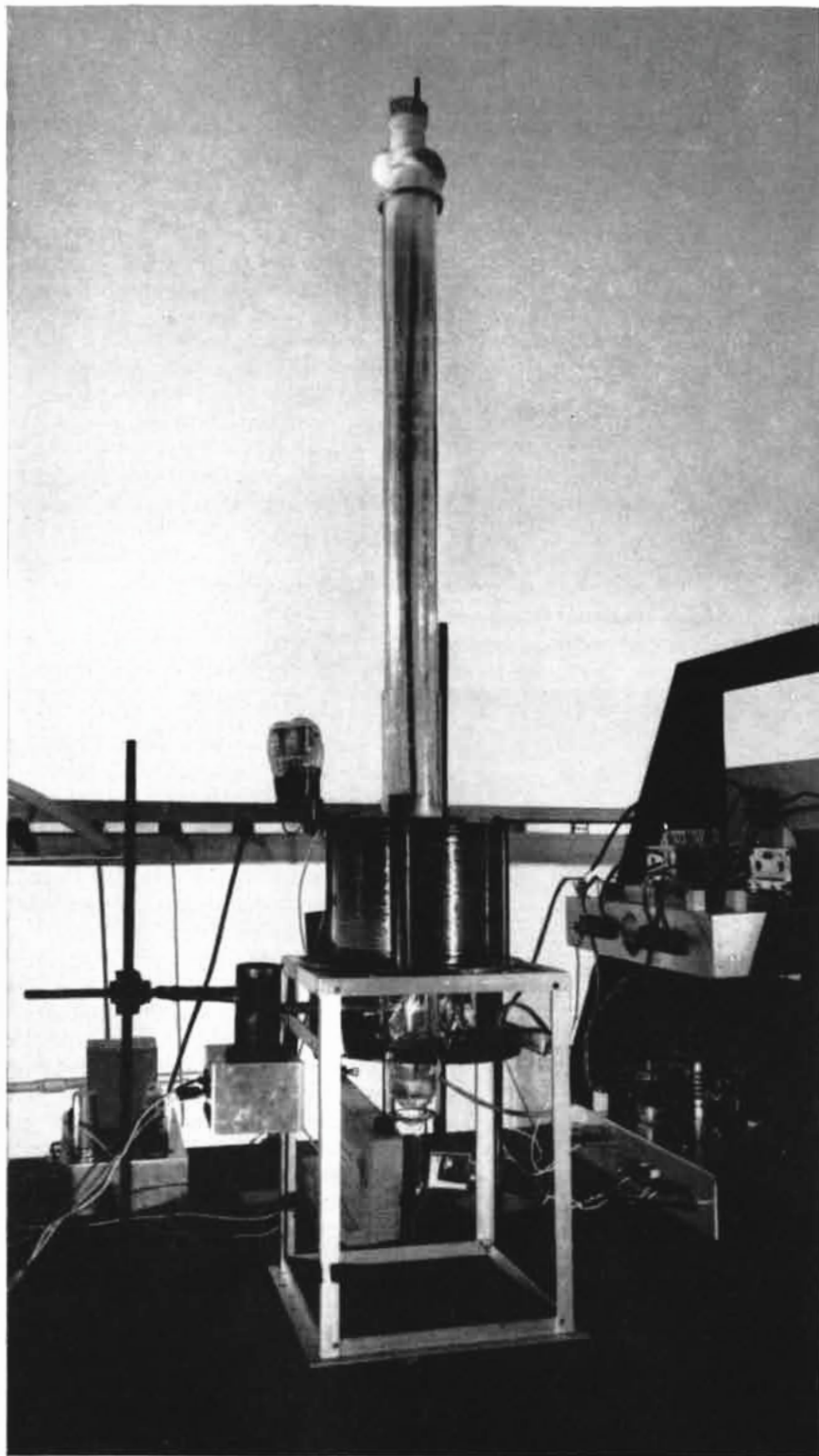

**HIGH-SPEED ROTATION DEVICE**, currently being used by the author, spins 1/64-inch spheres at a million r.p.s. Liquid helium surrounding the vacuum chamber holds the temperature near absolute zero so that gases freeze out, resulting in a near-perfect vacuum.

## NEW POLYMER CAN BE PROCESSED OR FABRICATED IN 13 WAYS

The LEXAN® polycarbonate resins — a new class of thermoplastic polymers — are unique in that they perform like thermosets in many respects, yet can be fabricated by the inexpensive techniques used with thermoplastics.

Their high impact strength, dimensional stability, heat resistance, electrical properties, and self extinguishing characteristic qualify them for roles formerly restricted largely to thermosets.

### Low-Cost Fabrication

Yet, as thermoplastics, they can be molded by injection, compression or transfer methods; extruded into shapes or film; blow molded, vacuum formed, cold worked, or solvent casted; made into coatings and laminates; welded, solvent cemented, bonded with adhesives.

The freedom to choose relatively inexpensive production methods when working with polycarbonates brings them into range of alternative engineering materials priced at far less per pound.

### G.E. Pioneered

General Electric introduced the polycarbonates 3 years ago as pilot plant materials. Today, a commercial plant for G.E.'s polycarbonate—LEXAN—is on-stream, and the company is offering a complete program of technical aid and literature.

For a better picture of where polycarbonate resin fits in your industry, send for "LEXAN Polycarbonate Resin" brochure No. A-1, charting properties in detail and illustrating many existing applications.

**LEXAN®**  
Polycarbonate Resin

**GENERAL ELECTRIC**  
Chemical Materials Dept., Sect. SA-3, Pittsfield, Mass.



PELLET IN VACUUM TUBE, along with ferrite magnetic core, is inserted in apparatus shown on preceding page. There the tube is surrounded by liquid helium to increase vacuum.

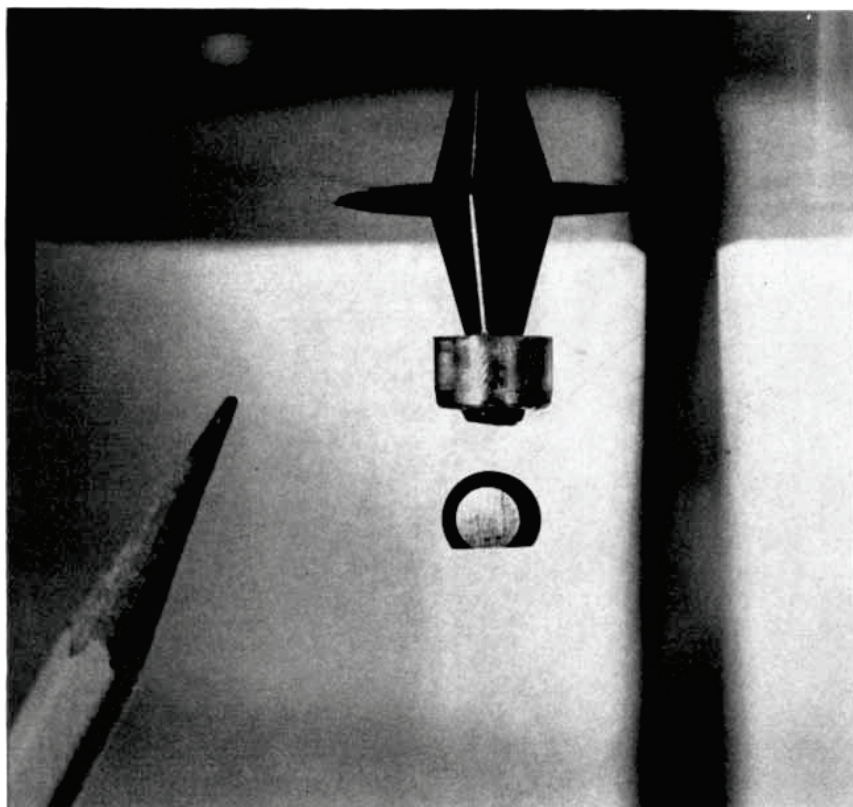

ROTOR WITH MIRROR FACE spins at 25,000 to 30,000 r.p.s., the speed being held constant to within one part in 100 million. Rotor is used for ultrahigh-speed photography.

material, are spun by the same electromagnetic forces that turn the armature of an induction or synchronous motor. Housed in a vacuum, the rotors are magnetically stabilized. The lines of force in the magnetic field parallel the axis of the rotor, but they diverge toward the bottom; consequently the rotor will seek the strongest part of the field and will tend to remain centered. Any residual motion is damped by hanging the steel cylindrical core of the supporting magnet in a dashpot of oil; if the rotor starts moving to one side, the core follows it and brings it back into proper position. In one system the vertical position of the rotor is monitored by the shadow the rotor casts on a photocell. A rise or fall in the rotor activates a circuit that makes an appropriate change in the strength of the electromagnet holding the rotor [see bottom illustration on page 140]. When everything is adjusted, no movement of the rotor, either horizontal or vertical, can be detected with a 100-power microscope.

The size of the rotor can be varied widely. We have supported and spun rotors ranging from less than a thousandth of an inch in diameter to more than a foot. Their weights have varied from about a billionth of a pound to more than 100 pounds.

The rotational speed at which a rotor will explode depends greatly upon the shape of the rotor and on the precision with which it is made. For carefully made rotors of the same shape, the bursting point is proportional to the mechanical strength of the material divided by its density. For example, when a series of steel spheres of different radii were spun to destruction we found that all exploded at the same peripheral speed, about 3,000 feet per second, or 2,000 m.p.h.

In this article there is room to touch on only a few applications of high-speed rotation. In one series of experiments performed with rotors spun to bursting speed we tested the strength of thin metal films. By electrodeposition we coated small cylindrical rotors with silver films of measured thickness. In some cases we sought maximum adhesion of film to rotor; in others we deliberately spoiled the adhesion by coating the rotors with albumin before the electrodeposition of film. In the latter the observed strength of the film is due solely to its inherent tensile strength.

In the tensile-strength experiments we found that for films thicker than six hundred-thousandths ( $6 \times 10^{-5}$ ) centimeter, strength is independent of thickness, being about equal to that of bulk

# The VISICORDER records transistor torture

Transistors often have to work under incredibly severe environmental conditions. Production-testing them gave engineers at Honeywell's Semiconductor Division a chance to exploit the great versatility of the 36-channel Visicorder oscillograph Model 1012.

A certain order of transistors had to withstand vibrations of 10G at 10 to 2,000 cps without failing during the test or as a result of it. A standard test had been to measure the transistor's performance, next subject it to non-active vibration (not in any circuit), and then re-measure. This approach was obviously deficient as it did not reveal *operating* characteristics during test, nor did it disclose *intermittent*-type failures.

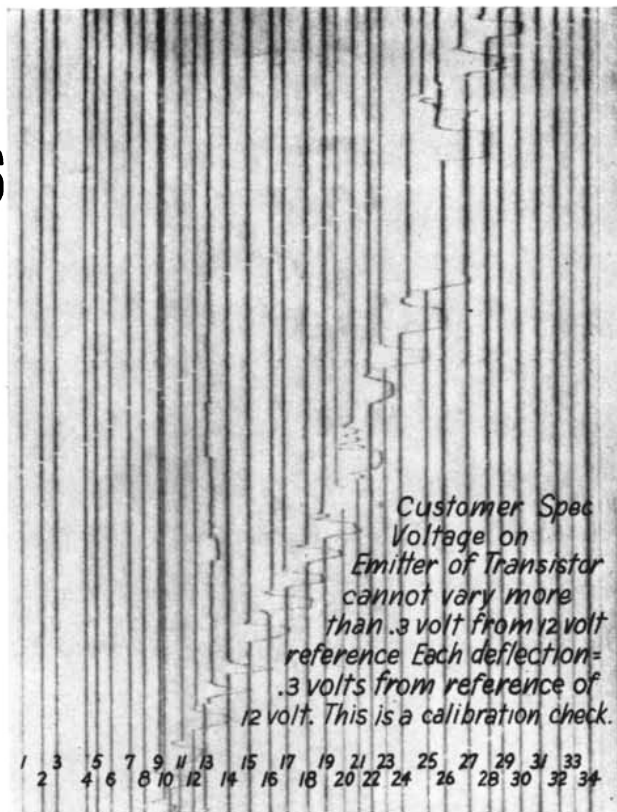

Unretouched record of vibration test on 36 transistors, each active in its own circuit during test.

The customer's quality requirements were stringent (AQL = .4%) and the large test sample required ruled out the use of an oscilloscope. The 3-hour test would have made a battery of scopes and operators necessary; transient defects would be missed due to eyestrain, fatigue, etc.

The Model 1012 Visicorder was chosen for the task as it simultaneously measures and records 36 channels of test information throughout the test period. The Visicorder instantly and directly records transients, no matter how random.

A Visicorder record like this is always a welcome supplement to your test data—your customer will be able to read it quickly and with full understanding. And it is a *permanent* record which *he* can show to *his* customer, if necessary.

For further information on how Visicorders can help to solve your instrumentation problems, contact your nearest Honeywell sales office without delay. Or write for Catalogs HC 906, 1012, 1108 and 1406, to:

Minneapolis-Honeywell, Heiland Division, 5200 East Evans, Denver 22, Colorado, SK 6-3681—Area Code:303

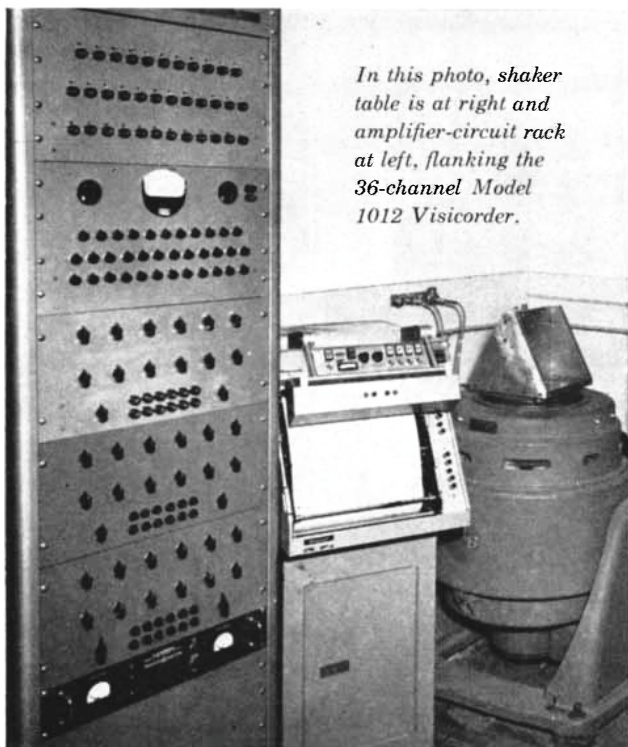

In this photo, shaker table is at right and amplifier-circuit rack at left, flanking the 36-channel Model 1012 Visicorder.

HONEYWELL INTERNATIONAL

Sales and Service offices in all principal cities of the world.

## Honeywell



Industrial Products Group

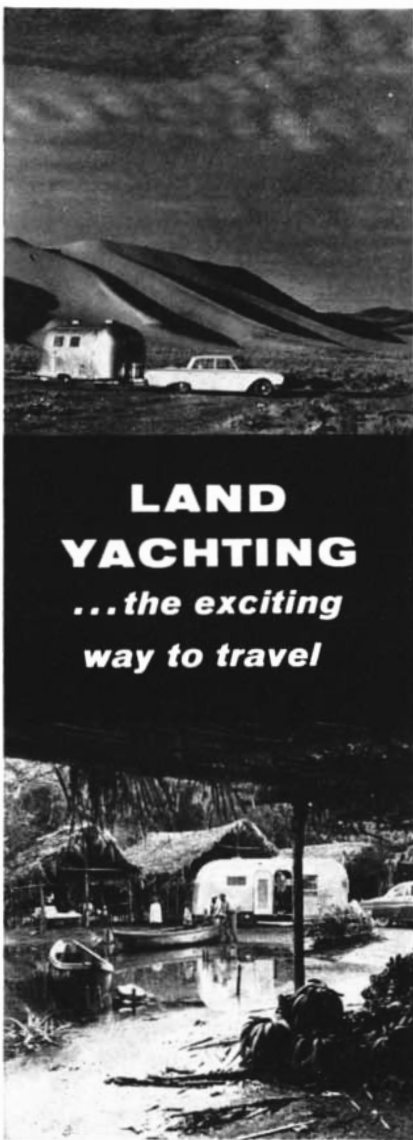

Want to escape to quiet, sunny deserts? Explore primitive native villages in Old Mexico or just relax beside some inviting stream? Perhaps you know a road somewhere you'd like to follow to the end. It's all the same with an Airstream Land Yacht — a personal highway cruiser outfitted down to the smallest luxurious detail for limitless road voyaging . . . good beds, bathroom, hot and cold water, refrigeration, heat and light independent of outside sources wherever you go — for a night, a week, or a month. Airstream Land Yachting means real travel independence — no time-tables, tickets, packing. You just tow your Airstream lightly behind your car and follow your travel whims wherever they urge you to go. Yes, it's the exciting, better way to travel here in North America or anywhere in the world.

*write for interesting free booklet  
"World At Your Doorstep"*

## **AIRSTREAM INC.**

600 CHURCH ST., JACKSON CENTER, OHIO  
12804 E. FIRESTONE, SANTA FE SPRINGS 46, CALIF.

silver. For films thinner than  $2.5 \times 10^{-5}$  cm., the tensile strength rises so sharply that the rotors will explode before the film breaks. The tensile strength of these thin films is at least 30 times that of bulk silver. Their strength seems largely attributable to the locking of crystal dis-

locations and to the difficulty of generating new dislocations in such thin material.

The widest use of high-speed rotation, of course, is to bring about sedimentation of substances differing either in size or in density. It is common knowledge

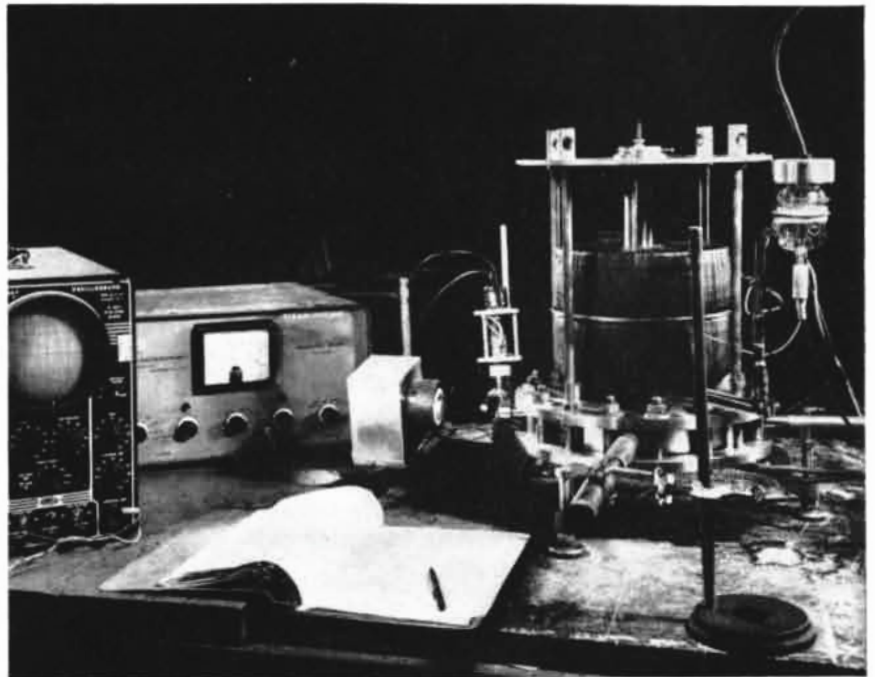

**HIGH-SPEED CENTRIFUGAL VACUUM PUMP** in top photograph achieves a vacuum so nearly perfect that no gauge can measure it. Stator and rotor of the pump appear in bottom photograph. Air molecules are whirled outward along rotor grooves, producing vacuum.

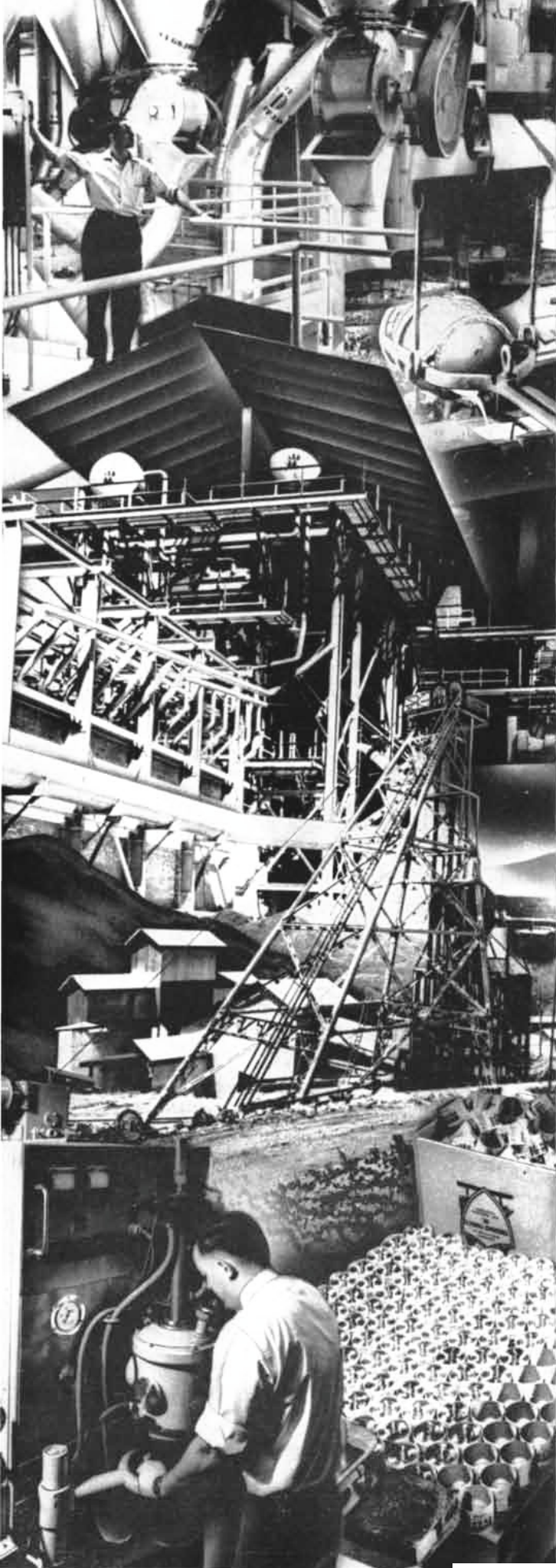

NEW YORK, April 2 -- IN THE 10-DAY PERIOD ENDED MARCH 28, ASARCO FILLED ORDERS FOR 22 BASIC COMMODITIES. THEY RANGED FROM 25 GRAMS OF HIGH PURITY ARSENIC TO 5,000,000 POUNDS OF LEAD. ASARCO ALONE AMONG WORLD PRODUCERS HAS ABILITIES AND FACILITIES TO EXTRACT, REFINE AND DELIVER SO MANY BASIC MATERIALS.

Aluminum	Lead
Antimony	Magnesium
Arsenic	Molybdenum
Asbestos	Concentrates
Bismuth	Nickel Sulfate
Cadmium	Platinum Metals
Copper	Selenium
Fluorspar	Silver
Germanium	Sulfuric Acid and
Concentrates	Sulfur Dioxide
Gold	Tellurium
Indium	Thallium
	Zinc

Asarco's vast technical knowledge of these and many other basic elements is available to help you solve your materials research and application problems. If you are planning a new product or re-designing one, call Asarco for assistance in producing it better, more economically. Write on your company letterhead to: PR Dept., American Smelting and Refining Company, 120 Broadway, New York 5, N. Y.



# ASARCO

© 1961 SCIENTIFIC AMERICAN, INC

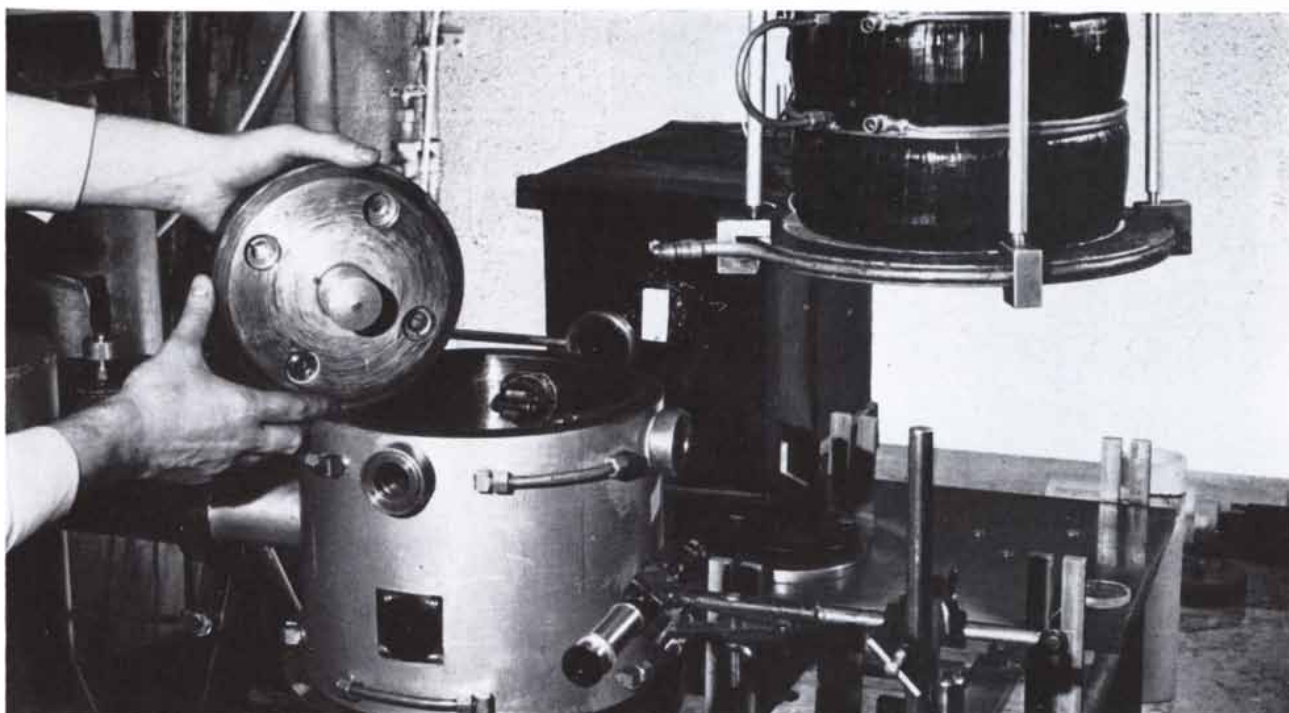

MOLECULAR WEIGHT DETERMINATIONS are made in an ultracentrifuge equipped with a special optical system (diagramed

below) that reveals sedimentation rate. The rotor has four openings: one sample cell, one light slit and a counterbalance for each.

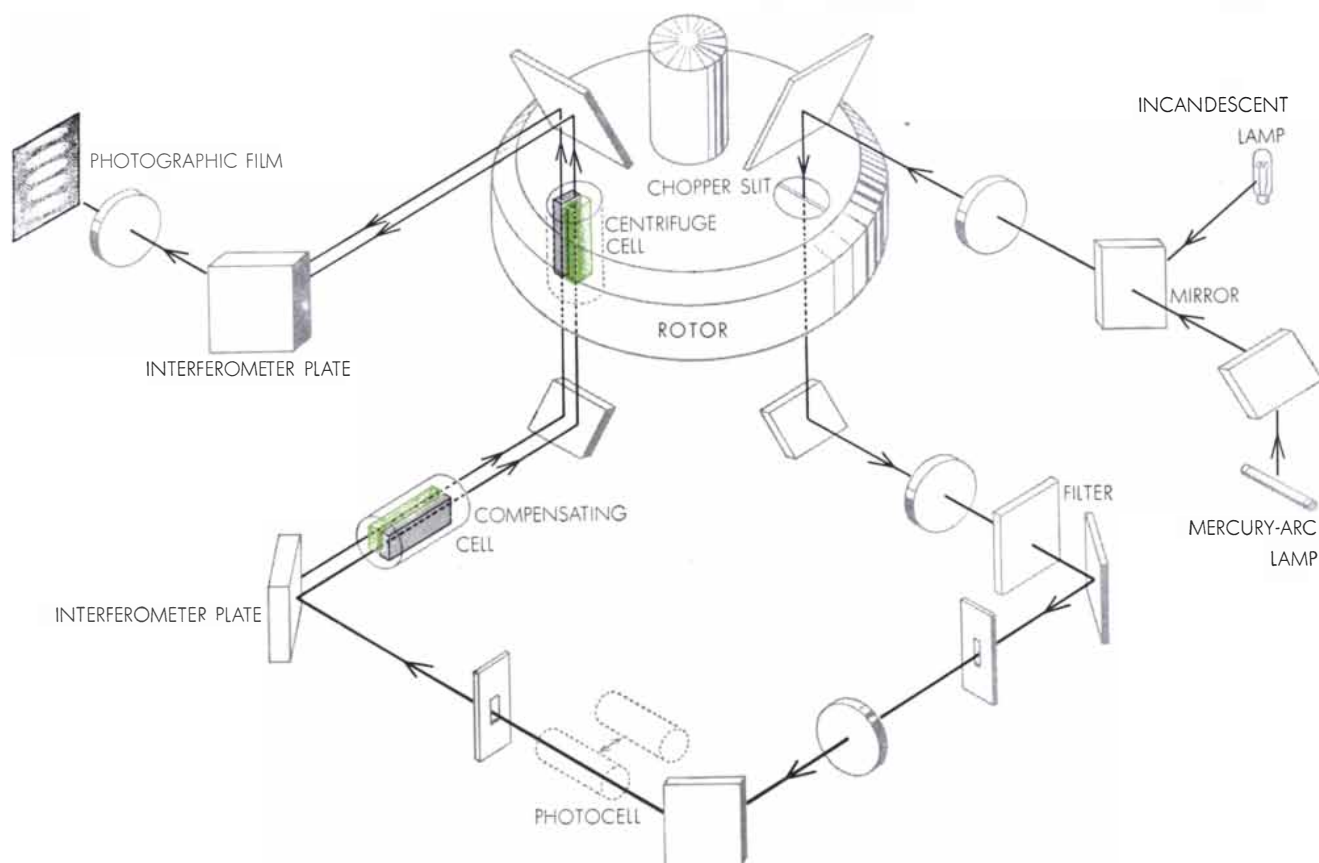

INTERFEROMETER SYSTEM splits one light beam into two, makes both travel through precisely same distance, then reunites them. One beam goes through a cell containing sample being measured (*color*), then through centrifuge cell holding only the solvent sample is dissolved in. Other beam travels first through solvent in compensating cell, then through sample in centrifuge (*color*). Op-

tical path of each beam is the same, except for differences caused by sample undergoing centrifugation. Light is refracted differently in different parts of centrifuge sample cell, producing interference pattern on film. Pattern shows rate of sedimentation, which depends upon molecular weight of sample. The two light sources are not used together; removal of mirror permits use of mercury arc.

that if one mixes up a thin slurry of mud, the heavier particles will settle first, followed by finer ones. If the force causing the particles to settle is doubled, the rate of settling doubles also. With very high centrifugal fields it is possible to throw most ordinary solids out of solution, though this may seem to violate the textbook definition of the term "solution."

Ordinary sugar, for example, stays in solution because it would take more than 100 years for a sugar molecule, suspended in water, to fall one millimeter in the earth's gravitational field. In actuality settling never even starts because the velocity of settling is many orders of magnitude smaller than the average velocity, due to thermal agitation, of all the molecules in the solution. However, if the solution is placed in a centrifugal field of a million *g*, the sugar molecules will have a sedimentation rate of two-thirds of a millimeter per hour. It is this great amplification of sedimentation rate that makes the ultracentrifuge useful for determining molecular weight. Modern ultracentrifuges are capable of determining molecular weights to a precision of much better than 1 per cent over the entire molecular weight region from about 50 to at least 100 million. A recent value obtained for sugar, for example, is 343, which compares very well with the value of 342.3 determined by other means. The centrifuge method is especially useful, of course, for determining the mass of large organic molecules.

As early as 1937 we were able to show at the University of Virginia that the isotopes of elements could be purified by centrifugation. The history of the great uranium separation plants at Oak Ridge testifies to the difficulty of the separation problem. Although a pilot plant for separating uranium 235 from uranium 238 by centrifugation was successfully operated at Bayway, N.J., early in World War II, the electromagnetic and gaseous-diffusion methods were finally selected for use at Oak Ridge. Within the past year, however, reports from Europe indicate a renewed interest in the centrifuge method as a possible way to obtain "cheap" fuel for nuclear reactors.

High-speed rotors provide the highest sustained speeds that can be achieved mechanically inside a small laboratory. They also provide the highest sustained accelerations attainable by any means. These two attributes make it certain that scientists and engineers will continue to find new uses for the techniques of ultra-high-speed rotation.

## The better data trap

By its very pioneering nature, research is forever in need of a new data-capturing device. And like as not the best answer will include some fresh, imaginative use of the sensing powers of photography.

For especially nowadays, when integrated with electronics and instant image processing, photography is well able to search out and present data that cannot be captured as fast, as accurately, or even at all by any other means.

Wherever photography can thus excel, we at Photomechanisms aim to provide our clients with the needed instrumentation, quickly and economically.

An indication of our competence appears in the brochure offered below. You will find that the devices shown there have two things in common with the instrument you are after. Each is the first of its kind...each has done a very notable data-recording job for the first time, in some major defense or civilian role.

Together, they may help you judge our ability to produce the new research tool—the better data trap—which you now need.

A postcard request will bring you the brochure. A letter outlining your special instrument need will receive our most thoughtful reply.

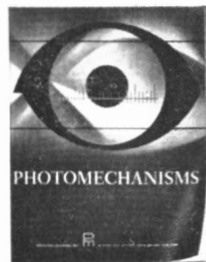

### Photomechanisms, INC.

Huntington Station, Long Island, New York

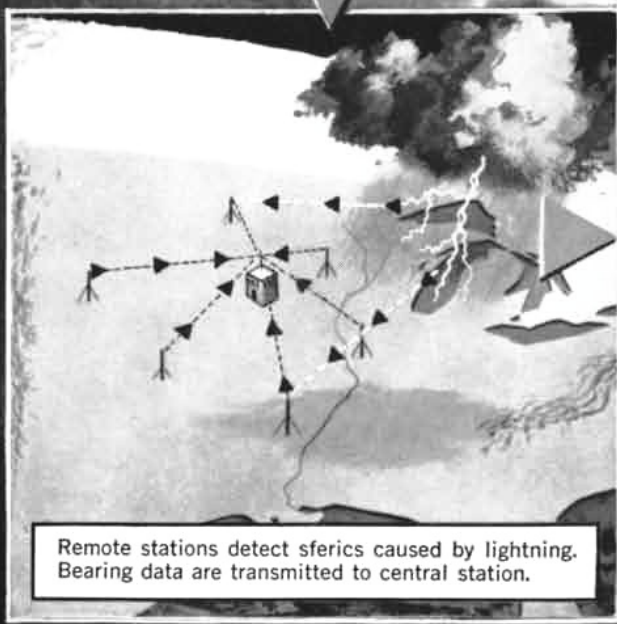
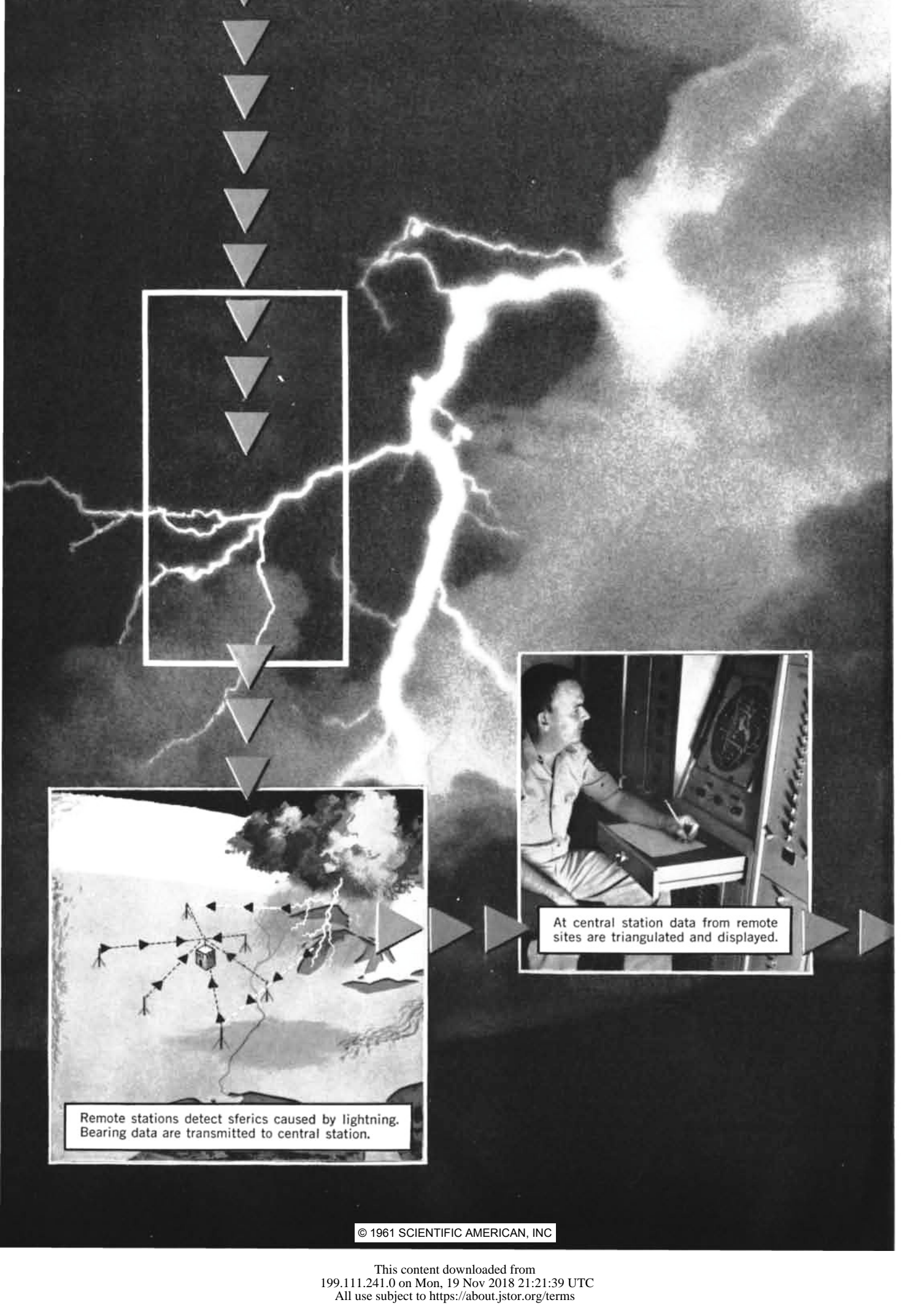

Remote stations detect sferics caused by lightning. Bearing data are transmitted to central station.



At central station data from remote sites are triangulated and displayed.



# Now... Forecasting by Lightning

**New Lockheed Electronics weather system  
spots storms up to 2,000 miles away**

When a storm is brewing, lightning may send warnings hours before it is detected by weather radar. Lightning flashes (sferics) give valuable clues to weather conditions, but until recently, weathermen had no effective way of detecting and locating sferics at long range.

Now, Lockheed Electronics has produced, in conjunction with the Army Signal Corps and Air Force, a unique system that pinpoints all lightning flashes within a 4,000-mile area.

Remote antennas pick up radio signals generated by sferics. Processing equipment converts the signals into directional data and transmits the information to the Air Force's Severe Weather Warning Center in Kansas City, Missouri. There, after triangulation, the signals are traced on a display which gives the storm's location and path.

Continuing research is leading to use of sferics as an aid in forecasting tornados and for plotting severe storms in mid-ocean where present forecasting devices cannot be used.

LEC is contributing importantly in a variety of ways to development of equipment to advance meteorological knowledge. Among current projects are high performance radiosondes and wind data conversion systems.

## **MINDING THE FUTURE**

# **LOCKHEED ELECTRONICS COMPANY**

**Plainfield, New Jersey**

### **ENGINEERS AND SCIENTISTS:**

For unique position advancement opportunities,  
please contact our Professional Placement Office.



Flashes of light  
on kinescope  
indicate lightning's location.